

1.2A LED driver with internal switch

GENERAL DESCRIPTION

The CL6808 is a continuous mode inductive step-down converter, designed for driving single or multiple series connected LEDs efficiently from a voltage source higher than the LED voltage. The device operates from an input supply between 7V and 40V and provides an externally adjustable output current of up to 1.2A. Depending upon supply voltage and external components, this can provide up to 35 watts of output power.

The CL6808 includes the output switch and a high-side output current sensing circuit, which uses an external resistor to set the nominal average output current.

Output current can be adjusted above, or below the set value, by applying an external control signal to the 'ADJ' pin. The ADJ pin will accept either a DC voltage or a PWM waveform. Depending upon the control frequency, this will provide either a continuous or a gated output current. The PWM filter components are contained within the chip.

The PWM filter provides a soft-start feature by controlling the rise of input/output current. The soft-start time can be increased using an external capacitor from the ADJ pin to ground.

Applying a voltage of 0.5V or lower to the ADJ pin turns the output off and switches the device into a low current standby state.

FEATURES

- ◆ Simple low parts count
- ◆ Wide input voltage range: 8V to 40V
- ◆ Up to 1.2A output current
- ◆ Single pin on/off and brightness control using DC voltage or PWM
- ◆ Typical 5% output current accuracy
- ◆ Inherent open-circuit LED protection
- ◆ High efficiency (up to 95%)
- ◆ High-Side Current Sense
- ◆ Soft-start
- ◆ Available in SOT89-5 packages

APPLICATIONS

- ◆ Low voltage halogen replacement LEDs
- ◆ Automotive lighting
- ◆ Low voltage industrial lighting
- ◆ LED back-up lighting
- ◆ Illuminated signs

TYPICAL APPLICATIONS

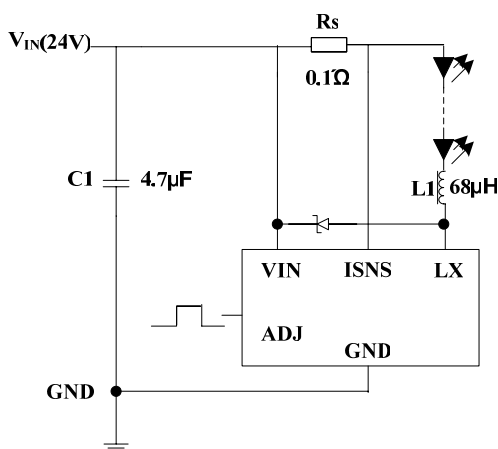

PIN ASSIGNMENT

SOT89-5

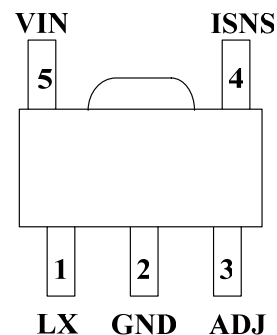

PIN DESCRIPTIONS

PIN NO.	PIN NAMES	DESCRIPTION
1	LX	Drain of the internal N-Ch MOSFET switch.
2	GND	Ground.
3	ADJ	Multi-function On/Off and brightness control pin: <ul style="list-style-type: none"> • Leave floating for normal operation (V_{ADJ} was internal pulled up) .average output current $I_{OUTnom} = 0.1/R_S$ • Drive to voltage below 0.4V to turn off output current • Drive with DC voltage ($0.5V < V_{ADJ} < 2.5V$) to adjust output current from 0% to 100% of I_{OUTnom} • Drive with PWM signal from open-collector or open-drain transistor, to adjust output current. Adjustment range 25% to 100% of I_{OUTnom} for $f > 10kHz$ and 1% to 100% of I_{OUTnom} for $f < 500Hz$ • Connect a capacitor from this pin to ground to increase soft-start time.
4	ISNS	Current sense input
5	VIN	Input Supply Pin. Must be locally bypassed

ABSOLUTE MAXIMUM RATINGS (note1)

SYMBOL	ITEMS	VALUE	UNIT
V_{IN}	Supply Voltage	-0.3~40	V
SW	Drain of the internal power switch	-0.3~40	V
ISNS	Current sense input (Respect to VIN)	+0.3~(-5.0)	V
ADJ	Logic level dimming input	-0.3~6	V
P_{DMAX}	Power Dissipation (Note 2)	Internally Limited	W
P_{TR}	Thermal Resistance, SOT89-5 θ_{JA}	45	$^{\circ}C/W$
T_J	Operation Junction Temperature Range	-40 to 150	$^{\circ}C$
T_{STG}	Storage Temperature	-55 to 150	$^{\circ}C$
	ESD Susceptibility (Note 3)	2	kV

RECOMMENDED OPERATING RANGE

SYMBOL	ITEMS	VALUE	UNIT
VIN	VDD Supply Voltage	0 ~ 30	V
TOPT	Operating Temperature	-40 to +85	$^{\circ}C$

Note 1: Absolute Maximum Ratings indicate limits beyond which damage to the device may occur. Recommended Operating Range indicates conditions for which the device is functional, but do not guarantee specific performance limits. Electrical Characteristics state DC and AC electrical specifications under particular test conditions which guarantee specific performance limits. This assumes that the device is within the Operating Range. Specifications are not guaranteed for parameters where no limit is given, however, the typical value is a good indication of device

performance.

Note 2: The maximum power dissipation must be derated at elevated temperatures and is dictated by T_{JMAX} , θ_{JA} , and the ambient temperature T_A . The maximum allowable power dissipation is $P_{DMAX} = (T_{JMAX} - T_A) / \theta_{JA}$ or the number given in Absolute Maximum Ratings, whichever is lower.

Note 3: Human body model, 100pF discharged through a 1.5kΩ resistor.

ELECTRICAL CHARACTERISTICS (Note 4, 5)

The following specifications apply for $V_{IN}=24V$, $T_A=25\text{ }^{\circ}C$, unless specified otherwise.

Symbol	Parameter	Conditions	Min.	Typ.	Max.	Unit
V_{IN}	Input Voltage		8		40	V
V_{UVLO}	Under voltage lock out	V_{IN} rising	6.5	7	7.5	V
V_{UVLO_HYS}	UVLO hysteresis	V_{IN} falling		500		mV
F_{SW}	Max. Switching Frequency				1	MHz
V_{ISNS}	Mean current sense threshold voltage	$V_{IN}-V_{ISNS}$	95	100	105	mV
V_{ISNS_hys}	Sense threshold hysteresis			±15		%
	Optional			±30		%
I_{ISNS}	ISNS Pin Input Current	$V_{IN}-V_{ISNS}=100mV$		8		μA
I_{OFF}	Quiescent supply current with output off			75		μA
I_{OP}	Quiescent supply current with output switching			1.8		mA
V_{ADJ_H}	ADJ input voltage High		2.5			V
V_{ADJ_L}	ADJ input voltage Low				0.5	V
V_{ADJ_DC}	DC brightness control		0.5		2.5	V
f_{ADJ}	Max. ADJ Frequency				20	kHz
D_{PWM_LF}	Duty cycle range of low frequency dimming	$f_{ADJ} < 500Hz$	0.01		1	
	Brightness control range			100:1		
D_{PWM_HF}	Duty cycle range of high frequency dimming	$f_{ADJ} > 10KHz$	0.2		1	
	Brightness control range			5:1		
I_{ADJ_H}	ADJ input leakage high	$V_{ADJ} = 5V$	-1		+1	uA
I_{ADJ_L}	Duty cycle range of high frequency dimming	$V_{ADJ} = 0$	0.2		1	
R_{LX}	LX On Resistance	$I_{LX}=1A$		0.5		Ω
I_{LXmean}	Continuous LX Current				1.2	A
I_{LEAK}	LX Leakage Current			0.5	5	μA

Note 4: Typical parameters are measured at 25°C and represent the parametric norm.

Note 5: Datasheet min/max specification limits are guaranteed by design, test, or statistical analysis.

SIMPLIFIED BLOCK DIAGRAM

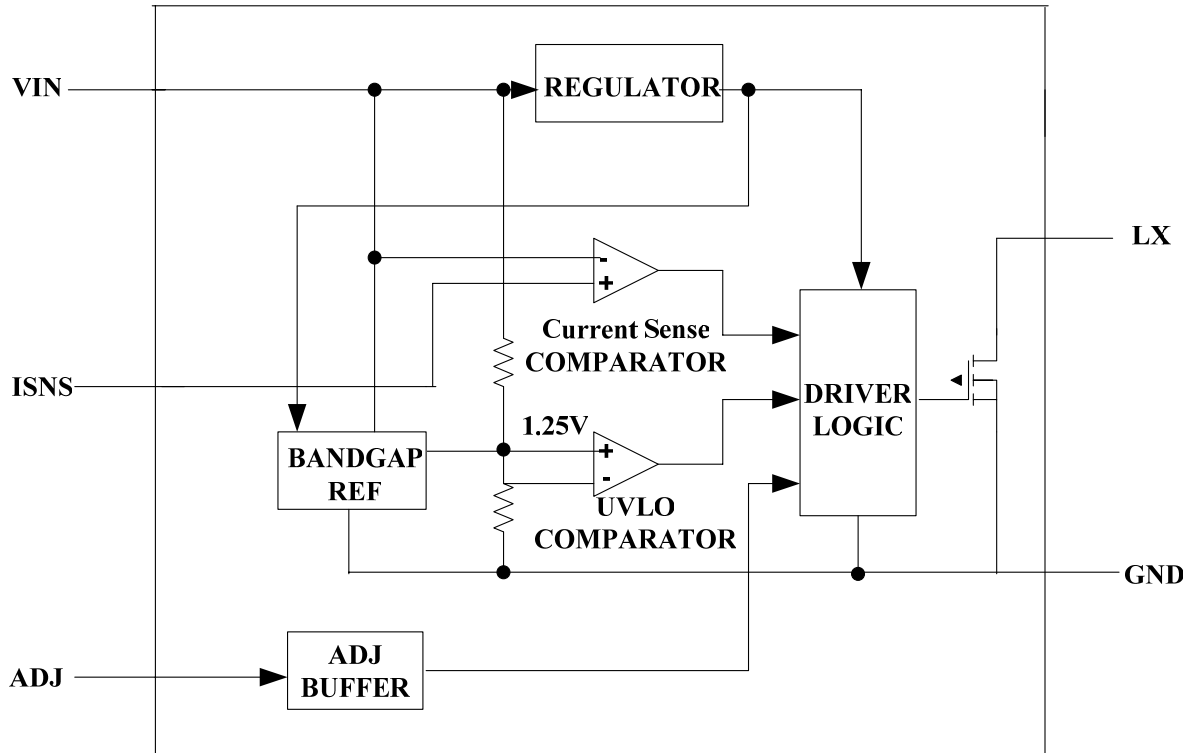

OPERATION DESCRIPTION

The CL6808 are step-down, constant current, high-brightness LED (HB LED) drivers. These devices operate from a 7V to 30V input voltage range and provide up to 1.2A sourcing LEDs. A highside current-sense resistor sets the output current and a dedicated PWM dimming input (ADJ) allows for a wide range of independent pulsed dimming. The high-side current-sensing scheme and on-board current-setting circuitry minimize the number of external components while delivering LED current with a $\pm 5\%$ accuracy, using a 1% sense resistor. The device, in conjunction with the coil (L1) and current sense resistor (RS), forms a self oscillating continuous-mode buck converter.

When input voltage VIN is first applied, the initial current in L1 and RS is zero and there is no output from the current sense circuit. Under this condition, the output of CS comparator is high. This turns MN on and switches the LX pin low, causing current to flow from VIN to ground, via RS, L1 and the LED(s). The current rises at a rate determined by VIN and L1 to produce a voltage ramp (V_{ISNS}) across RS. When $(V_{IN} - V_{ISNS}) > 115\text{mV}$, the output of CS comparator switches low and MN turns off. The current flowing on the RS decreases at another rate. When $(V_{IN} - V_{ISNS}) < 85\text{mV}$, the MN turns on again and the mean current on the LED is determined by $((85 + 115)/2 \text{ mV}) / R_S = 100\text{mV} / R_S$.

The high-side current-sensing scheme and on-board current-setting circuitry minimize the number of external components while delivering LED current with $\pm 5\%$ accuracy, using a 1% sense resistor.

The CL6808 allow dimming with a PWM signal at the ADJ input. A logic level below 0.3V at ADJ forces CL6808 to turn off the LED and the logic level at ADJ must be at least 2.5V to turn on the

LED current.

The ADJ pin can be driven by an external dc voltage (V_{ADJ}) to adjust the output current to a value below the nominal average value defined by R_S .

High luminance LEDs often need to be supplied with a temperature compensated current in order to maintain stable and reliable operation at all drive levels. The LEDs are usually mounted remotely from the device so, for this reason, the temperature coefficients of the internal circuits for the CL6808 have been optimized to minimize the change in output current when no compensation is employed. If output current compensation is required, it is possible to use an external temperature sensing network - normally using Negative Temperature Coefficient (NTC) thermistors and/or diodes, mounted very close to the LED(s). The output of the sensing network can be used to drive the ADJ pin in order to reduce output current with increasing temperature.

Undervoltage Lockout (UVLO)

The CL6808 include a 7V undervoltage lockout (UVLO) with 500mV hysteresis. When V_{IN} falls below 7V, turning off the internal n-channel MOSFET. MOSFET is on once V_{IN} is 7.5V or higher.

5V Regulator

VCC is the output of a 5V regulator capable of sourcing 10mA. VCC was bypassed to GND with internal capacitor.

ADJ Input

The CL6808 allow dimming with a PWM signal at the ADJ input. A logic level below 0.5V at ADJ turns off the LED current. To turn the LED current on, the logic level at ADJ must be at least 2.5V.

APPLICATION DESCRIPTION

Selecting R_{SENSE} to Set the LED Current

The CL6808 feature a programmable LED current using a resistor connected between V_{IN} and I_{SNS} . Use the following equation to calculate the sense resistor:

$$I_{out} = \frac{0.1 \times V_{ADJ}}{2.5 \times R_S} \quad (0.5V \leq V_{ADJ} \leq 2.5V)$$

Current Regulator Operation

The CL6808 regulate the LED output current using an input comparator with hysteresis (Figure 1). As the current through the inductor ramps up and the voltage across the sense resistor reaches the upper threshold, turns off the internal MOSFET. The MOSFET turns on again when the inductor current ramps down through the freewheeling diode until the voltage across the sense resistor equals the lower threshold. Use the following equation to determine the operating frequency:

$$f_{sw} = \frac{(V_{IN} - n \times V_{LED}) \times n \times V_{LED} \times R_{SENSE}}{V_{IN} \times \Delta V \times L}$$

where n = number of LEDs, V_{LED} = forward voltage drop of one LED, and $\Delta V = (V_{SNS_HI} - V_{SNS_LO})$.

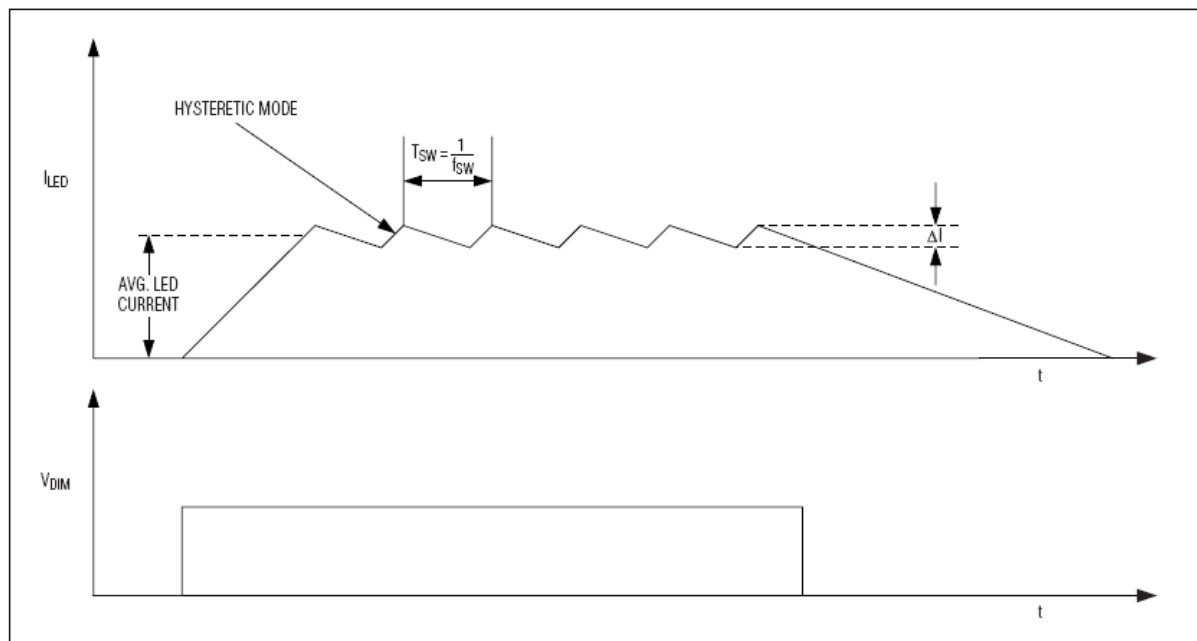

Figure 1. Current Regulator Operation

Freewheeling Diode Selection

The forward voltage of the freewheeling diode should be as low as possible for better efficiency. A Schottky diode is a good choice as long as the breakdown voltage is high enough to withstand the maximum operating voltage. The forward current rating of the diode must be at least equal to the maximum LED current.

LED Current Ripple

The LED current ripple is equal to the inductor current ripple. In cases when a lower LED current ripple is needed, a capacitor can be placed across the LED terminals.

PCB Layout Guidelines

Careful PCB layout is critical to achieve low switching losses and stable operation. Use a multilayer board whenever possible for better noise immunity. Minimize ground noise by connecting high-current ground returns, the input bypass-capacitor ground lead, and the output-filter ground lead to a single point (star ground configuration). In normal operation, there are two power loops. One is formed when the internal MOSFET is on and the high current flows through IN—R_{SENSE}—LEDs—Inductor—MOSFET—GND. The other loop is formed when the internal MOSFET is off when the high current circulates through R_{SENSE}—LEDs—Inductor—freewheeling diode. To minimize noise interaction, each loop area should be as small as possible. Place R_{SENSE} as close as possible to the input filter and VIN. For better noise immunity, a Kelvin connection is strongly recommended between ISNS and R_{SENSE}. Connect the exposed paddle to a large-area ground plane for improved power dissipation.

PACKAGE INFORMATION

SOT89-5 Package

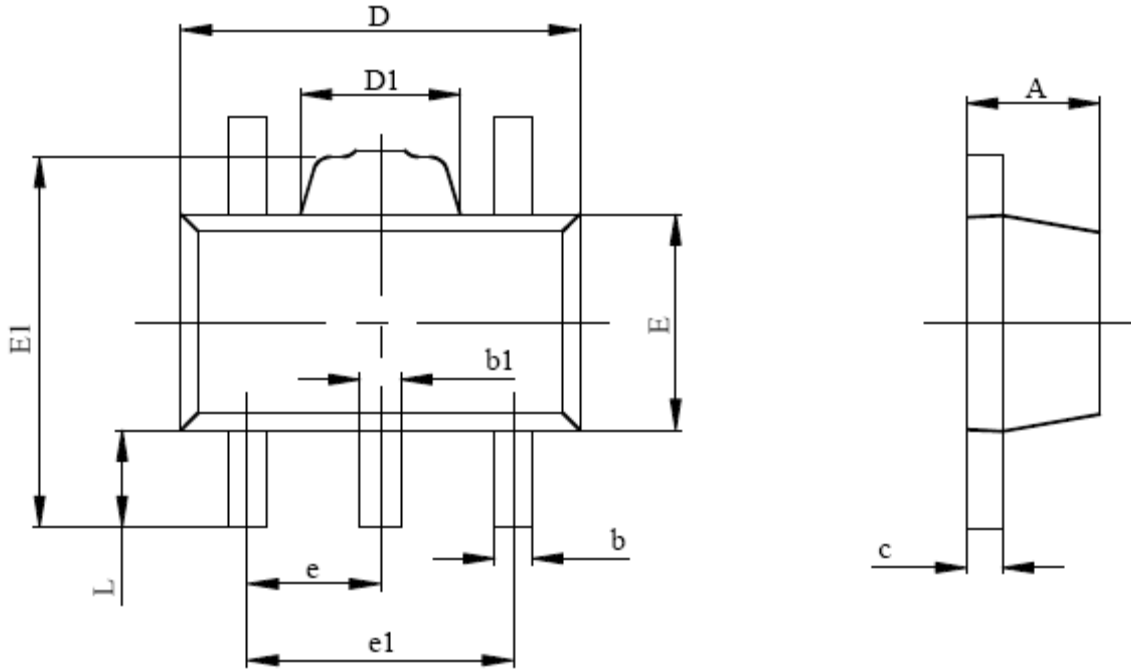

Symbol	Millimeters	
	Min	Max
A	1.400	1.600
b	0.320	0.520
b1	0.360	0.560
c	0.350	0.440
D	4.400	4.600
D1	1.400	1.800
E	2.300	2.600
E1	3.940	4.250
e	1500 TYP	
e1	2.900	3.100
L	0.900	1.100

- The information described herein is subject to change without notice.
- CHIPLINK Technology is not responsible for any problems caused by circuits or diagrams described herein whose related industrial properties, patents, or other rights belong to third parties. The application circuit examples explain typical applications of the products, and do not guarantee the success of any specific mass-production design.
- When the products described herein are regulated products subject to the Wassenaar Arrangement or other agreements, they may not be exported without authorization from the appropriate governmental authority.
- Use of the information described herein for other purposes and/or reproduction or copying without the express permission of CHIPLINK Technology is strictly prohibited.
- The products described herein cannot be used as part of any device or equipment affecting the human body, such as exercise equipment, medical equipment, security systems, gas equipment, or any apparatus installed in airplanes and other vehicles, without prior written permission of CHIPLINK Technology.
- Although CHIPLINK Technology exerts the greatest possible effort to ensure high quality and reliability, the failure or malfunction of semiconductor products may occur. The user of these products should therefore give thorough consideration to safety design, including redundancy, fire-prevention measures, and malfunction prevention, to prevent any accidents, fires, or community damage that may ensue.